

# **BIDDER'S PROPOSAL SHEET**

## **Select Sidewalk Replacement Project and Miscellaneous Site Work in the Town of Sullivan**

---

---

**BID PRICE: \$** \_\_\_\_\_  
(enter dollar amount)

\_\_\_\_\_  
(enter dollar amount in words)

**Detailed specifications must accompany the bid. The Town Board of the  
Town of Sullivan reserves the right to determine if any bid is acceptable  
and to reject all bids.**

\_\_\_\_\_  
(Bidder's Company Name)

\_\_\_\_\_  
(Authorized Representative)

\_\_\_\_\_  
(Address)

\_\_\_\_\_  
(Phone Number)                      \_\_\_\_\_  
(Email Address)

\_\_\_\_\_  
(Authorized Signature)

\_\_\_\_\_  
(Title)                                      \_\_\_\_\_  
(Date)

**NON-COLLUSIVE BIDDING CERTIFICATE**  
*(Select Sidewalk Replacement Project and  
Miscellaneous Site Work in the Town of Sullivan)*

By submission of this bid, the bidder and each person signing on behalf of the bidder, certifies under penalty of perjury, to their best knowledge and belief:

1. The price(s) in this bid, was arrived at independently without collusion, consultation, communication or agreement, for the purpose of restricting competition, as to any matter relating to such price(s) with any other bidder or with any competitor;
2. Unless otherwise required by law, the price(s) which has been quoted in the bid has not ~~been knowingly disclosed by the bidder and will not knowingly be disclosed by the bidder prior to opening, directly or indirectly, to any other bidder or to any competitor; and~~
3. No attempt has been made or will be made by the bidder to induce any other person, partnership or corporation to submit or not to submit a bid for the purpose of restricting competition.

The preceding statement, known and executed by the undersigned, is affirmed as true and attached to the bid submitted herewith under the penalties of perjury of the State of New York.

\_\_\_\_\_  
(Bidder Name)

\_\_\_\_\_  
(Authorized Representative)

\_\_\_\_\_  
(Bidder Address)

\_\_\_\_\_  
(Bidder Phone Number)

\_\_\_\_\_  
(Bidder Email Address)

\_\_\_\_\_  
(Authorized Signature)

\_\_\_\_\_  
(Title)

\_\_\_\_\_  
(Date)

(Corporate Seal)

**TOWN OF SULLIVAN**  
**GENERAL CONDITIONS AND INSTRUCTIONS TO BIDDERS**  
*(Select Sidewalk Replacement Project and  
Miscellaneous Site Work in the Town of Sullivan)*

1. Bids must be received by 5:00 p.m. on the 15<sup>th</sup> day of December, 2021, at the Town of Sullivan Town Clerk's Office, 7507 Lakeport Road, Chittenango, New York 13037.
2. Specifications and Form of Bid may be obtained from the Town Clerk at the above listed address.
3. Bids must be in a sealed envelope clearly marked:

---

---

**“SELECT SIDEWALK REPLACEMENT PROJECT AND  
MISCELLANEOUS SITE WORK IN THE TOWN OF SULLIVAN  
BID PACKAGE, Dated: December 15, 2021”**

4. Bids must include a completed Non-Collusive Bidding Certificate.
5. Bidder must specify a “Completion Date” of May 30, 2022 and perform accordingly.
6. A copy of any warranty must accompany the bid. Said warranty must not commence until the “Completion Date” of May 30, 2022.
7. To be considered complete, a set of specifications must accompany each bid unit.
8. The Town Board of the Town of Sullivan reserves the right to complete discretion regarding all bids.
9. To receive consideration, all deviations from specifications must be listed in detail on the bid proposal sheet. Any bid containing deviations from the norm that are not clearly noted and fully explained, will not be considered a complete bid.
10. The contract for “*Select Sidewalk Replacement Project and Miscellaneous Site Work in the Town of Sullivan*” shall be awarded to the lowest responsive, responsible bidder. In cases where two or more bidders submit identically priced bids, the Town Board reserves the right to award the contract to either bidder at their discretion.
11. The Town Board reserves the right to reject any or all bids or re-advertise for new bids at their discretion.
12. Any bid may be withdrawn at any time prior to the bid submittal deadline. Bids may be withdrawn only when written authorization is presented after submittal.
13. Prevailing Wage Rates: All work must comply with Section 220 of the New York State Labor Law, as applicable. This is a public works project. Prevailing Wage Rates may be obtained at [www.labor.ny.gov](http://www.labor.ny.gov).
14. Price quoted shall be net, less all taxes and shall include delivery, all transportation and delivery charges pre-paid to destination.
15. The successful bidder shall agree, upon award of the Contract not to assign or sublet this Contract or any interest therein without first obtaining the written consent of the Town Purchasing Agent.

16. In case of default by the bidder or contractor, the Town of Sullivan may procure the article or services from other sources without notice and hold the bidder and/or contractor thereby responsible for any excess costs occasioned by the default.
17. The bidder, if awarded a contract, agrees to protect, defend, and save harmless the Town of Sullivan against any demand for payments for the use of any patented material, process, article, or device, that may enter into the manufacture, construction, or from a part of the work covered by the contract: and further agrees to indemnify and save harmless the Town from suits or actions of every nature and description brought against it, for or on account of any injuries or demands received or sustained by any group or parties, by or from any acts of the contractor, his servants, or agents.
18. Laws, Rules and Regulations of the State of New York and all Local Law, Rules and Regulations, insofar as they apply to Competitive Bidding, Contracts and Purchases, are made a part hereof.
19. Qualifications of Bidders: In determining the qualifications of a bidder, the Town of Sullivan will consider bidder's record in the performance of any contracts in which they may have entered with the Town of Sullivan, with other public bodies or private corporations, and the Town of Sullivan expressly reserves the right to reject the bid of such bidder if such record discloses that such bidder, in the opinion of the Town of Sullivan, has not properly performed such contracts or has habitually and without just cause neglected the payment of bills or has otherwise disregarded his obligations to subcontractors, material suppliers or employees.

The Town of Sullivan may make such investigations as it may deem necessary to determine the ability of the bidder to perform the work and the bidder shall furnish to the Town of Sullivan all such information and data for this purpose as the Town of Sullivan may request following the bid opening. The Town of Sullivan reserves the right to reject any bid if the evidence submitted by, or determined by the investigation of, such bidder fails to satisfy the Town of Sullivan that such bidder is properly qualified to carry out the obligations of the Contract, and to complete the work contemplated therein.

The bidder shall have a minimum of three (3) years' experience in the provision of similar concrete work.

20. Conditions of Work: Each bidder shall acquaint themselves fully with the site conditions relating to the construction of the project, the employment of labor and the laws and regulations governing the safe and proper execution of the work. Failure to do so will not relieve a successful bidder from bidder's obligation to furnish all material, labor and equipment necessary to carry out the provisions of the Contract.
21. Final Contract will include requirements for submission of performance and payment bonds.
22. Certified Payrolls: Certified payrolls must accompany all invoices and must be kept up to date. Certified payrolls should be sent to the Town of Sullivan Comptroller, 7507 Lakeport Road, Chittenango, New York 13037.
23. Contact Person: Hon. John Becker, Town of Sullivan Supervisor, (315) 687-9190  
Ms. Beth Ellis, Town of Sullivan Comptroller, (315) 687-9190

**TOWN OF SULLIVAN**  
**SELECT SIDEWALK REPLACEMENT PROJECT AND**  
**MISCELLANEOUS SITE WORK IN THE TOWN OF SULLIVAN**

Bids are requested from responsible Bidders for the *Select Sidewalk Replacement Project and Miscellaneous Site Work in the Town of Sullivan* project located at: 1) the Town of Sullivan Parks and Recreation Building (located at 707 Legion Drive); and 2) the New York State Police Building (located at 7507 Lakeport Road) both located in Chittenango, New York 13037.

**SCOPE**

*Supply all materials and labor to install replacement sidewalks, grading, handrails, asphalt paving, etc., all as set forth in the project documents.*

It is the intent of these specifications that the bidder shall include all labor, materials, equipment, services and transportation for the work to be undertaken. All workmen shall be skilled and qualified for the work they perform. All materials used, unless otherwise specified, shall be new and of the types and grades specified.

**REQUIREMENTS**

- The work shall be warranted by the contractor for a minimum of three (3) years after final acceptance.
- The successful bidder will provide a performance bond equal to 100% of the bid, as well as a bid bond equal to 5% of the bid amount.
- Contractor will complete all work under this contract in ninety (90) days from Notice to Proceed. Contractor's failure to complete all work under this contract in ninety (90) days from Notice to Proceed will result in Contractor forfeiting all or a portion of the performance bond in the discretion of the Town Board of the Town of Sullivan.
- Contractor will pay workers in accordance with the Prevailing Wage Schedule. Certified payrolls will be provided to the Town indicating compliance with this requirement.
- Contractor will provide evidence of appropriate insurance coverage as follows:
  - Workmen's Compensation Insurance Coverage
  - Liability Insurance - \$1,000,000.00 each occurrence and \$3,000,000.00 annual aggregate
  - Automobile - \$1,000,000.00
  - Owner's Protective Liability Policy in the name of the Town of Sullivan of at least \$2,000,000.00
  - Disability Benefits per New York State Requirements.
- The required insurance policies shall be endorsed to include the Town of Sullivan as an additional insured. Also, to include the provisions that the issuing company(s) will notify the Certificate of Insurance Holder, who shall be the Town of Sullivan, 7507 Lakeport Road, Chittinango, New York 13037, by certified mail thirty (30) days prior to any change diminishing coverage, limits, cancellation or non-renewal of the insurance policies. For

the duration of the awarded contract, the issuing company(s) shall notify the Certificate of Insurance Holder upon renewal of the policies.

- Payments: Town of Sullivan will pay the successful bidder the amount of their bid upon the full and faithful performance of the contract, acceptance of materials and/or work by the Town of Sullivan, and upon receipt of the vendor invoices and lien releases, as applicable.

Unless otherwise specified, Town of Sullivan may in any contract involving construction work or labor retain up to five percent (5%) of the amount of the contract (or ten percent (10%) of the final payment amount, whichever is greater) until final completion and acceptance of all work covered by the contract.

The successful bidder further agrees that Town of Sullivan may withhold, out of any amounts due the contractor, sums sufficient to cover any unpaid claims by mechanics or laborers for work or labor performed under this contract, provided that the notice in writing of such claims, signed by the claimants, shall have been previously filed.

The successful bidder further agrees that they shall not be entitled to demand or receive any payment except in the manner set forth in this bid or any contract entered into.

- Warranty: Town of Sullivan requires a minimum three (3) years warranty from the date of acceptance, to correct at no additional cost to Town of Sullivan any failure or defect in material and workmanship, which appears in the equipment, goods or services supplied under this bid.

Town of Sullivan does not accept exceptions to implied warranties of suitability or merchantability. Town of Sullivan does not accept limitations for recovery for incidental or consequential damages or on its legal remedies to secure such recovery.

- Termination/Default/Non-Performance: In case of default by the successful bidder, Town of Sullivan may procure the articles or services from other courses without notice and hold the bidder responsible for any excess cost.

Town of Sullivan may terminate this agreement with cause upon notification in writing.

Town of Sullivan further may terminate the contract without cause on 30 days' notice in writing. Upon notice, the contractor will cease all services in connection with performance of this agreement and shall proceed to cancel all existing contracts insofar as such contracts are chargeable to this agreement.

If the successful bidder is delayed in making delivery by strikes, lockouts, fire, or unusual delay by common carriers control, then the time of delivery may be extended for a reasonable time after receipt of a written documented request by the contractor. This request must be approved and responded to in writing by the Town of Sullivan. Town of Sullivan may cancel said contract as to future deliveries at any time during such delay if Town of Sullivan interests are impaired by such delay.

Neither an extension of time for any reason, beyond that fixed herein for the performance of the contract, nor the doing and acceptance of any part of the work, or the supplies nor materials called for by the contract, shall be deemed to be a waiver by Town of Sullivan of the right to terminate this contracts for abandonment or delay.

- Changes/Deviations: This bid as well as any contract, plans, drawings, exhibits or schedule to which are attached and made a part of the bid constitutes the entire agreement and understanding between the parties hereto and shall be binding upon each party as their successors. Any additions, changes or deviations to or from said specifications, contracts, plans, drawings, exhibits or schedule will invalidate the agreement between the parties in its entirety unless in every case such changes shall be previously made in writing agreed upon by the parties hereto in consideration of all applicable legislation.

**SPECIFICATIONS**

*Available at the Town of Sullivan Town Hall, 7507 Lakeport Road, Chittenango, New York 13037.*

---

---

**Town of Sullivan  
Chittenango, New York**

***Select Sidewalk Replacement Project and  
Miscellaneous Site Work in the Town of Sullivan***

**ADVERTISEMENT FOR BIDS**

Sealed Bids for Town of Sullivan Sidewalk Replacement Project will be received by the ***Town of Sullivan***, at the office of the ***Town Clerk*** until 5:00 p.m. local time on December 15, 2021 at which time the Bids received will be publicly opened and read aloud. The Town Board reserves the right to delay the Bid Award for up to 30 days.

The project is located at: 1) the Town of Sullivan Parks and Recreation Building, located at 707 Legion Drive, Chittenango, New York; and 2) the State Police Building, located at 7507 Lakeport Road, Chittenango, New York, in the Town of Sullivan. The scope of work is set forth in the project documents which can be found at the Town of Sullivan Town Hall, 7507 Lakeport Road, Chittenango, New York, and includes ***the installation of concrete sidewalks, site work, grading, asphalt paving, installation of aluminum handrails and other work referenced in the project documents.***

The Bid Documents may be examined beginning November 18, 2021 at the following locations:

***Town of Sullivan Town Hall, 7507 Lakeport Road, Chittenango, New York***

Copies of the Bid Documents (including specifications) may be obtained starting November 18, 2021 at the issuing office:

***Town of Sullivan Town Hall, 7507 Lakeport Road, Chittenango, New York  
(315) 687-9190.***

Bid security in the form of a Bid Bond, Certified Check, Bank Cashier/Teller/Treasurer's Check payable to the "Town of Sullivan" in the amount of 5% of the total bid amount must accompany each proposal as a guarantee that if the proposal is accepted, a contract will be entered into.

Bidders' attention is referred particularly to all state and local governing laws and regulations, including applicable Affirmative Action Requirements, Equal Employment Opportunity, and Minimum Wage Rate Requirements to be paid under the Contract, and Prevailing Wage Rate Requirements to be paid under this Contract.

The Town reserves the right to waive any and all irregularities, and to reject any and all bids, or to rebid the project solely at the Town Board's discretion.

Contact: ***John Becker, Town of Sullivan Supervisor (315) 687-9190***  
***Beth Ellis, Town of Sullivan Comptroller (315) 687-9190***



**TOWN OF SULLIVAN  
TOWN BOARD RESOLUTION**

**November 17, 2021**

**AUTHORIZATION FOR THE ADVERTISEMENT AND SOLICITATION OF BIDS  
FOR A SELECT SIDEWALK REPLACEMENT PROJECT AND  
MISCELLANEOUS SITE WORK IN THE TOWN OF SULLIVAN**

The following resolution was offered by \_\_\_\_\_, who moved its adoption, seconded by \_\_\_\_\_, to wit:

---

**WHEREAS**, the Town of Sullivan has previously advised of the need to replace select sidewalks and other miscellaneous site work within the Town of Sullivan, including but not limited to the replacement of sidewalks, grading, handrails, asphalt paving, etc. (all as set forth in the project documents) at the Town of Sullivan Parks and Recreation Building located at 707 Legion Drive and at the New York State Police Building located at 7507 Lakeport Road, both in Chittenango, New York 13037; and

**WHEREAS**, the proposal is for the materials and labor to install replacement sidewalks, grading, handrails, asphalt paving, etc., all as set forth in the project documents; and

**WHEREAS**, the proposed procurement and replacement project has been determined to be a Type II action pursuant to SEQR; and

**WHEREAS**, the Town Board has directed the preparation of an advertisement for bids and bid documents for the select sidewalk replacement project and miscellaneous site work in accordance with all applicable New York State Code Requirements; and

**WHEREAS**, said advertisement for bids shall be let by the Town by placing a notice on the Town's website and further through advertisement and mailings, as directed by the Town Board; and

**WHEREAS**, copies of the proposed advertisement for bids and bid specification documents shall be filed in the Town Clerk's Office and said notice shall advise of the availability of said documents at the Town Hall located 7507 Lakeport Road, Chittenango, New York 13037.

**NOW, THEREFORE, BE IT RESOLVED** that the Town of Sullivan Town Board hereby directs the advertisement for bids for the materials and labor to install replacement sidewalks, grading, handrails, asphalt paving, etc. at the Town of Sullivan Parks and Recreation Building located at 707 Legion Drive and at the New York State Police Building located at 7507 Lakeport Road, both in Chittenango, New York 13037 (all as more particularly described in the bid documents), all in accordance with all applicable New York State Building Code Requirements and the issuance of bid documents for response to said bids, with a bidder return date and bid opening on December 15, 2021 at 5:00 p.m. at the Town of Sullivan Town Hall located at 7507 Lakeport Road, Chittenango, New York 13037, at which time any responsive bids shall be publicly opened and read aloud; and it is further

**RESOLVED** that said bid documentation shall reserve the right of the Town of Sullivan to reject all bids and to rebid the project at the Town Board's sole discretion.

\*\*\*\*\*

**Town of Sullivan  
Chittenango, New York**

***Select Sidewalk Replacement Project and  
Miscellaneous Site Work in the Town of Sullivan***

**ADVERTISEMENT FOR BIDS**

Sealed Bids for Town of Sullivan Sidewalk Replacement Project will be received by the ***Town of Sullivan***, at the office of the ***Town Clerk*** until 5:00 p.m. local time on December 15, 2021 at which time the Bids received will be publicly opened and read aloud. The Town Board reserves the right to delay the Bid Award for up to 30 days.

The project is located at: 1) the Town of Sullivan Parks and Recreation Building, located at 707 Legion Drive, Chittenango, New York; and 2) the State Police Building, located at 7507 Lakeport Road, Chittenango, New York, in the Town of Sullivan. The scope of work is set

forth in the project documents which can be found at the Town of Sullivan Town Hall, 7507 Lakeport Road, Chittenango, New York, and includes *the installation of concrete sidewalks, site work, grading, asphalt paving, installation of aluminum handrails and other work referenced in the project documents.*

The Bid Documents may be examined beginning November 18, 2021 at the following locations:

***Town of Sullivan Town Hall, 7507 Lakeport Road, Chittenango, New York***

Copies of the Bid Documents (including specifications) may be obtained starting November 18, 2021 at the issuing office:

***Town of Sullivan Town Hall, 7507 Lakeport Road, Chittenango, New York  
(315) 687-9190.***

Bid security in the form of a Bid Bond, Certified Check, Bank Cashier/Teller/Treasurer's Check payable to the "Town of Sullivan" in the amount of 5% of the total bid amount must accompany each proposal as a guarantee that if the proposal is accepted, a contract will be entered into.

Bidders' attention is referred particularly to all state and local governing laws and regulations, including applicable Affirmative Action Requirements, Equal Employment Opportunity, and Minimum Wage Rate Requirements to be paid under the Contract, and Prevailing Wage Rate Requirements to be paid under this Contract.

The Town reserves the right to waive any and all irregularities, and to reject any and all bids, or to rebid the project solely at the Town Board's discretion.

Contact: ***John Becker, Town of Sullivan Supervisor (315) 687-9190***  
***Beth Ellis, Town of Sullivan Comptroller (315) 687-9190***

\*\*\*\*\*

The question of the adoption of the foregoing resolution was duly put to a vote and upon roll call, the vote was as follows:

<b>John E. Brzuszkiewicz</b>	<b>Councilor</b>	<b>Voted</b>	<b>Yes</b>
<b>Thomas J. Kopp Jr.</b>	<b>Councilor</b>	<b>Voted</b>	<b>Yes</b>
<b>Kerry Ranger</b>	<b>Councilor</b>	<b>Voted</b>	<b>Yes</b>
<b>Jeffrey Martin</b>	<b>Councilor</b>	<b>Voted</b>	<b>Yes</b>
<b>John M. Becker</b>	<b>Supervisor</b>	<b>Voted</b>	<b>Yes</b>

The foregoing resolution was thereupon declared duly adopted.

**DATED: November 17, 2021**

**CERTIFICATE**

**STATE OF NEW YORK    )**  
**COUNTY OF MADISON    )**

I, the undersigned Deputy Town Clerk of the Town of Sullivan, Madison County, New York, **DO HEREBY CERTIFY:**

That I have compared the foregoing Resolution with the original thereof on file in the Office of the Town Clerk of the Town of Sullivan, and that the same is a true and correct copy of said original and of the whole of said original so far as the same relates to the subject matters therein referred to.

**I FURTHER CERTIFY** that all members of said Board had due notice of said meeting and that, pursuant to Section 103 of the Public Officers Law, said meeting was open to the general public.

**IN WITNESS WHEREOF**, I have hereunto set my hand and affixed the seal of said Town on November \_\_\_\_, 2021

\_\_\_\_\_  
**JILL DOSS, Deputy Town Clerk**

(SEAL)

**SELECT SIDEWALK REPLACEMENT**  
TOWN OF SULLIVAN, MADISON COUNTY  
7507 LAKEPORT ROAD  
CHITTENANGO, NY 13037

Project Name	Client	Date
SELECT SIDEWALK REPLACEMENT	TOWN OF SULLIVAN	MAY 27, 2021

Date: MAY 27, 2021  
**L000**



AREA 'D'



AREA 'B'



AREA 'A'



AREA 'C'

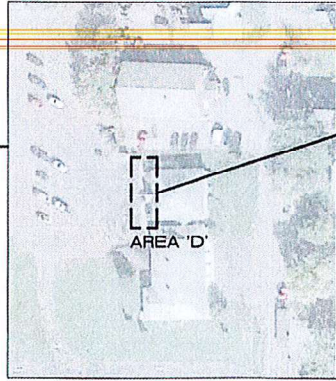

STATE POLICE BUILDING  
7507 LAKEPORT ROAD  
CHITTENANGO NY 13037

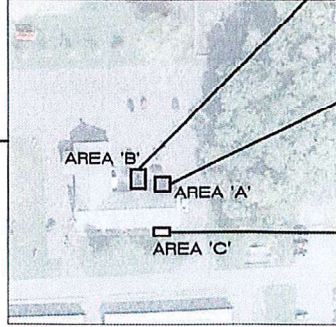

PARKS AND RECREATION BUILDING  
707 LEGION DRIVE  
CHITTENANGO NY 13037

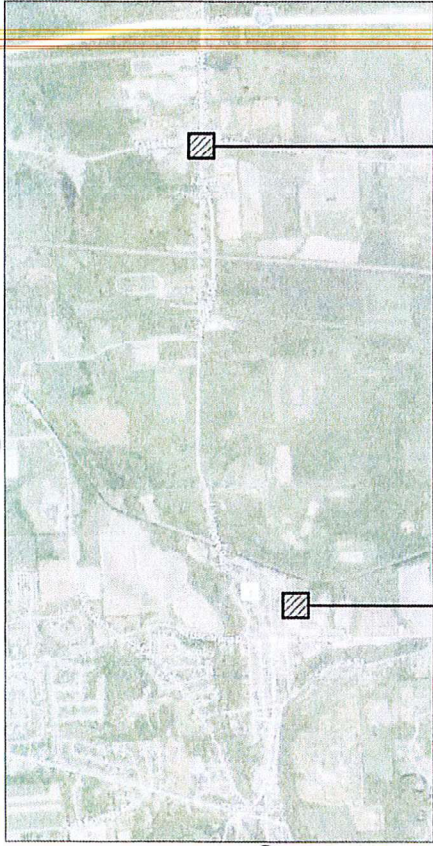

LOCATION PLAN

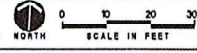

**SITE PREPARATION and CONSTRUCTION NOTES**

- ① EXISTING LAWN AREA REMAINS. PROTECT.
- ② EXISTING VEGETATION REMAINS. PROTECT AT ALL TIMES AS SHOWN ON THE PLANS AND AS SPECIFIED. DO NOT PARK VEHICLE/EQUIPMENT OR STORE MATERIALS WITHIN DROP LINES OF TREES.
- ③ EXISTING PAVEMENT REMAINS. PROTECT. REPLACE ANY PAVEMENT DAMAGED DURING CONSTRUCTION.
- ④ REMOVE EXISTING PAVEMENT SURFACE AND GRANULAR BASE COURSE. HALL OFF SITE.
- ⑤ EXISTING SITE FEATURE REMAINS. PROTECT.
- ⑥ REMOVE EXISTING SITE FEATURE AND DISPOSE OFF SITE, INCLUDING ANY ASSOCIATED FOOTINGS OR UNDERDRAINS. BACKFILL VOID WITH FROTTED GRANULAR BACKFILL, COMPACTED TO 98% OF IN PLACE DRY DENSITY.
- ⑦ SAW CUT NEAT, STRAIGHT EDGE. PRIOR TO PAVING, AT SIDEWALKS REMOVE AT NEAREST SCORE JOINT.
- ⑧ HEFT EXISTING LINE AND GRADE.
- ⑨ SIDEWALKS SHALL BE INSTALLED WITH LONGITUDINAL SLOPE NO GREATER THAN 2%, AND CROSS-SLOPE OF NO GREATER THAN 2%, UNLESS HEFTING EXISTING GRADE.
- ⑩ 6" SLIP DOSEL NEW CONCRETE GALK INTO EXISTING CONCRETE GALK OR BUILDING FOUNDATION WALL WITH NO. 4 SLIP DOSEL, 18" LONG, 12" O.C., 2" CLEAR FROM FINISH FLOOR SURFACE. INSERT DOSELS EQUAL LENGTH INTO EXISTING AND NEW CONCRETE. PROVIDE EXPANSION JOINT AND SEALANT.
- ⑪ ALIGN NEW EDGE WITH EXISTING.
- ⑫ PROVIDE HOT TAR ASPHALT CRACK SEALER BETWEEN EXISTING AND NEW ASPHALT JOINT.
- ⑬ REPAIR ALL LAWN SURFACES DISTURBED BY THE REMOVAL AND INSTALLATION OF CONCRETE GALKS. PROVIDE A SURFACE FREE OF DEPRESSIONS. THIS INCLUDES, BUT IS NOT LIMITED TO, SPREADING TOPSOIL, FILL LEVELING, AND SEEDING LAWN WITHIN DISTURBED AREAS.

**LEGEND**

EXISTING	PROPOSED	DESCRIPTION
		CONCRETE/GRANITE CURB
		PAVEMENT EDGE
		SAW CUT LINE
		SPOT GRADE
		FIELD VERIFY
		TYPICAL
		CURB RAMP w/ DETECTABLE WARNINGS
		REMOVE EXISTING PAVEMENT
		MEDIUM DUTY ASPHALT
		CONCRETE WITH SCORING

appel  
osborne  
landscape  
architecture  
interior  
design  
www.aos.com

**SELECT SIDEWALK REPLACEMENT**  
TOWN OF SULLIVAN, MADISON COUNTY  
7877 LAURETT ROAD  
CATTARAUGUS, NY 14807

Project No.	1001
Sheet No.	1001
Date	10/10/10
Scale	AS SHOWN
Author	APP/OSB
Checker	APP/OSB
Engineer	APP/OSB
Professional Seal No.	
Professional Seal State	

**L001**

**SELECT SIDEWALK REPLACEMENT**  
TOWN OF SULLIVAN, MADISON COUNTY  
7567 LANGPORT ROAD  
CHITTENANGO, NY 13037

Project No.	
Client	
Scale	
Date	
Author	
Checker	
Appr. by	
Project Manager	

Date: MAY 21, 2007  
**L002**

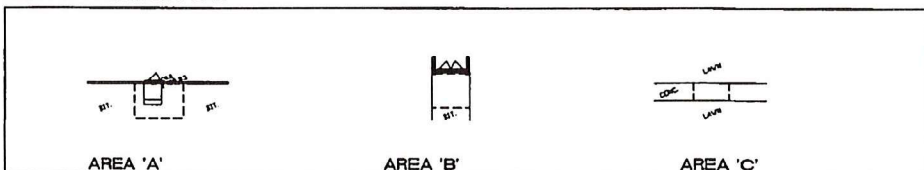
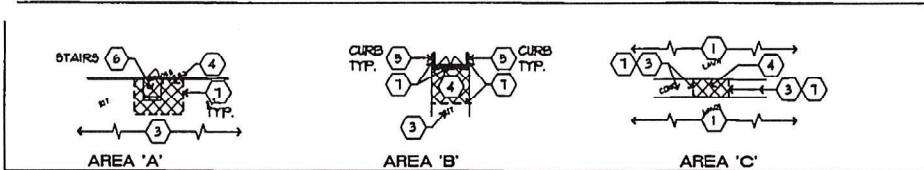
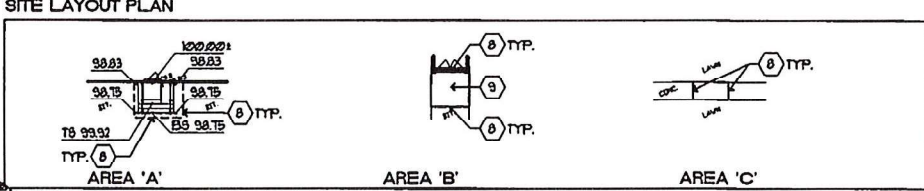
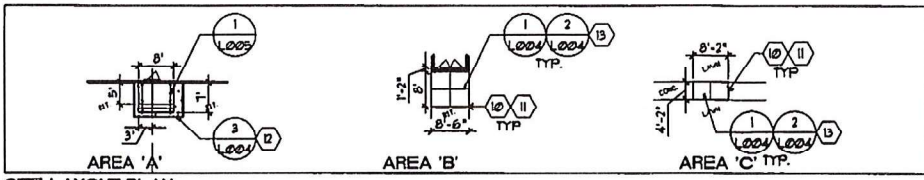

TOWN OF SULLIVAN - PARKS AND RECREATION BUILDING

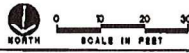

Project No.	
Client	
Location	
Date	
Scale	
Author	
Checker	
Appr.	

Date: MAY 11, 2003  
**L003**  
Page 1 of 1

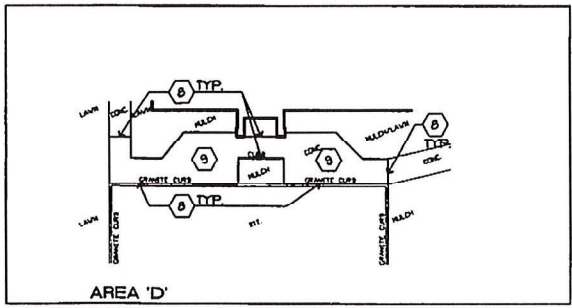
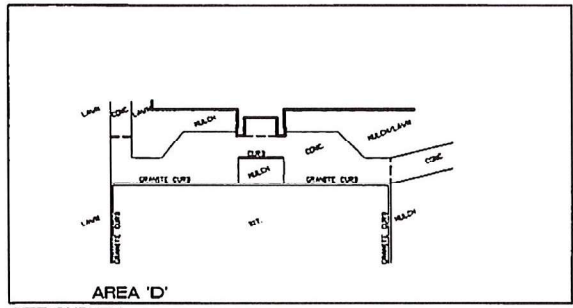
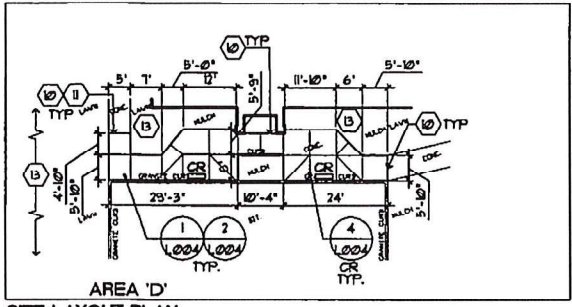
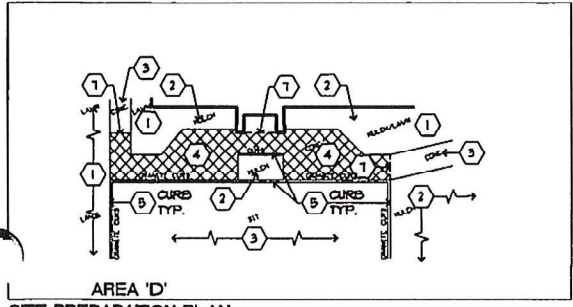

TOWN OF SULLIVAN - STATE POLICE BUILDING





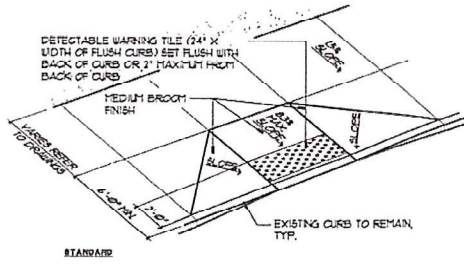

**4 CURB RAMP WITH DETECTABLE WARNING SYSTEM**  
 L004 SECTION - NOT TO SCALE 310-001  
 © APFL OSBORNE LANDSCAPE ARCHITECTURE

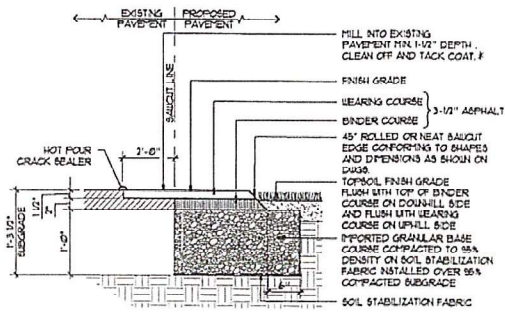

**3 MEDIUM DUTY ASPHALT PAVEMENT = MDA**  
 L004 SECTION - NOT TO SCALE 310-002  
 © APFL OSBORNE LANDSCAPE ARCHITECTURE

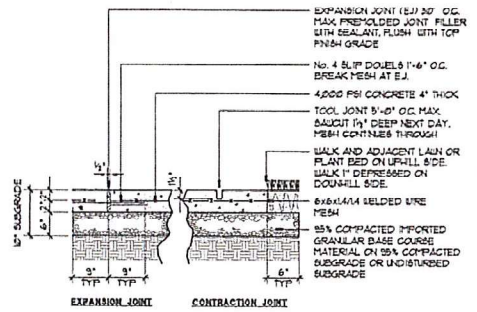

**2 CONCRETE WALK - STANDARD**  
 L004 SECTION - NOT TO SCALE 310-003  
 © APFL OSBORNE LANDSCAPE ARCHITECTURE

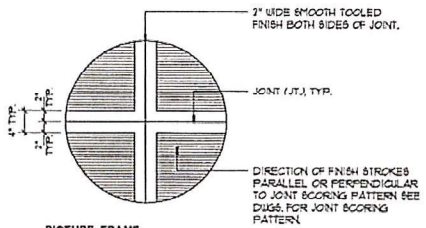

**1 CONCRETE WALK AND FINISHED PAD**  
 L004 SECTION - NOT TO SCALE 310-001  
 © APFL OSBORNE LANDSCAPE ARCHITECTURE

Page Number	Date	By
1	02/11/10	APFL
2	02/11/10	APFL
3	02/11/10	APFL
4	02/11/10	APFL
5	02/11/10	APFL
6	02/11/10	APFL
7	02/11/10	APFL
8	02/11/10	APFL
9	02/11/10	APFL
10	02/11/10	APFL

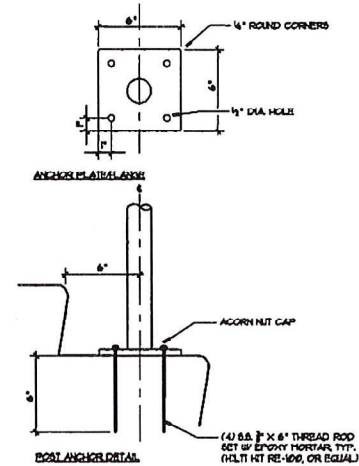
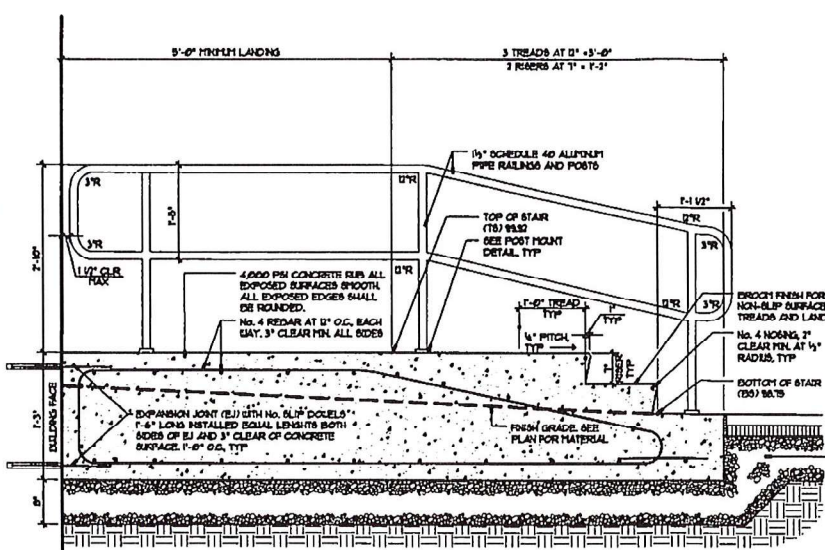

NOTE: NO VOID SPACE IN STAIRS

**1 CONCRETE STAIRS AND ALUMINUM HANDRAIL**

L005 SECTION - NOT TO SCALE 3/10-10/10

APPEL OSBORNE LANDSCAPE ARCHITECTURE

appel  
osborne  
landscape  
architecture  
INCORPORATED

**SELECT SIDEWALK REPLACEMENT**  
TOWN OF SULLIVAN, MADISON COUNTY  
7577 LAKEPORT ROAD  
CHITTENANGO, NY 13027

Project No.	1005
Sheet No.	1005-1
Date	10/10/10
Scale	AS SHOWN
Author	APPEL OSBORNE
Checker	APPEL OSBORNE
Engineer	APPEL OSBORNE

**L005**